

IWC-XCS-AT-01
SCALE 1:2

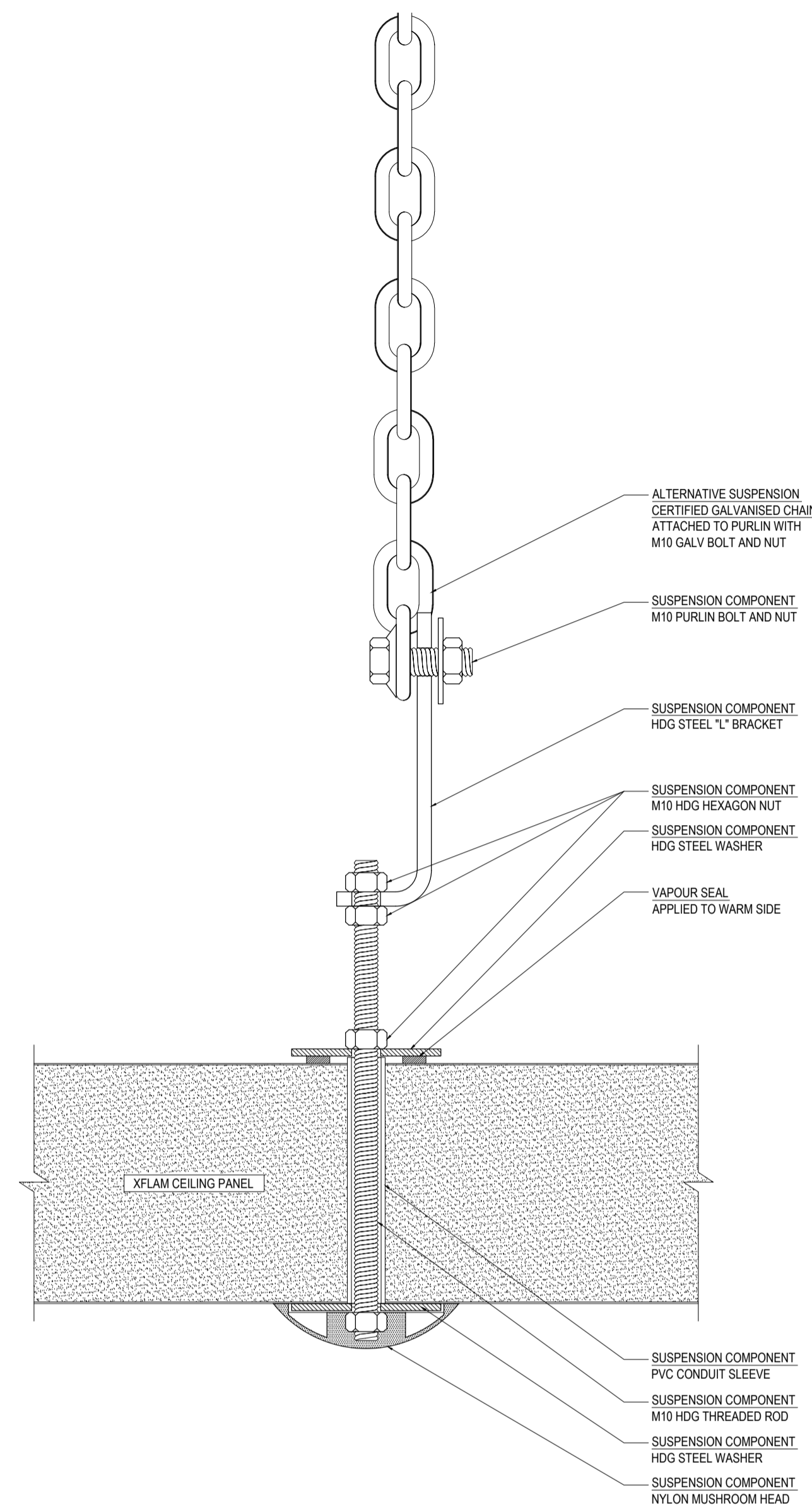

IWC-XCS-AT-02
SCALE 1:2

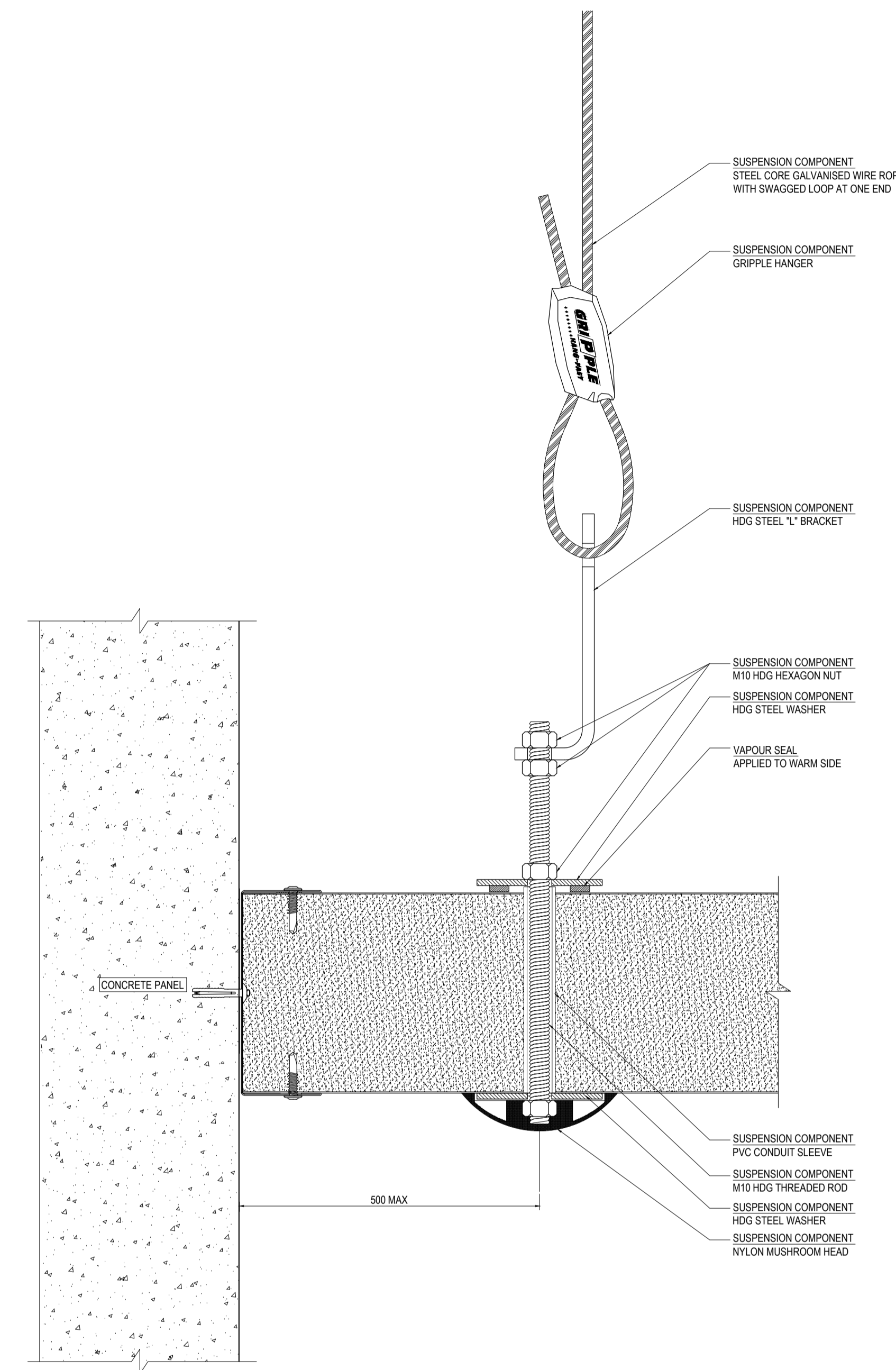

IWC-XCS-AT-03
SCALE 1:2

© copyright

Revision		
-	-	-
-	-	-
-	-	-
-	-	-
-	-	-

Title

**Standard Details
Ceiling Suspension
Ambient Temperature
(15°C and Above)**

Checked By	AS	Scale	1:2
Drawn By	RV	Sheet size	A1
Issue date	22.01.2013	Revision	A
Drawing No.	IWC-XCS-AT		
Sheet	1 of 11		

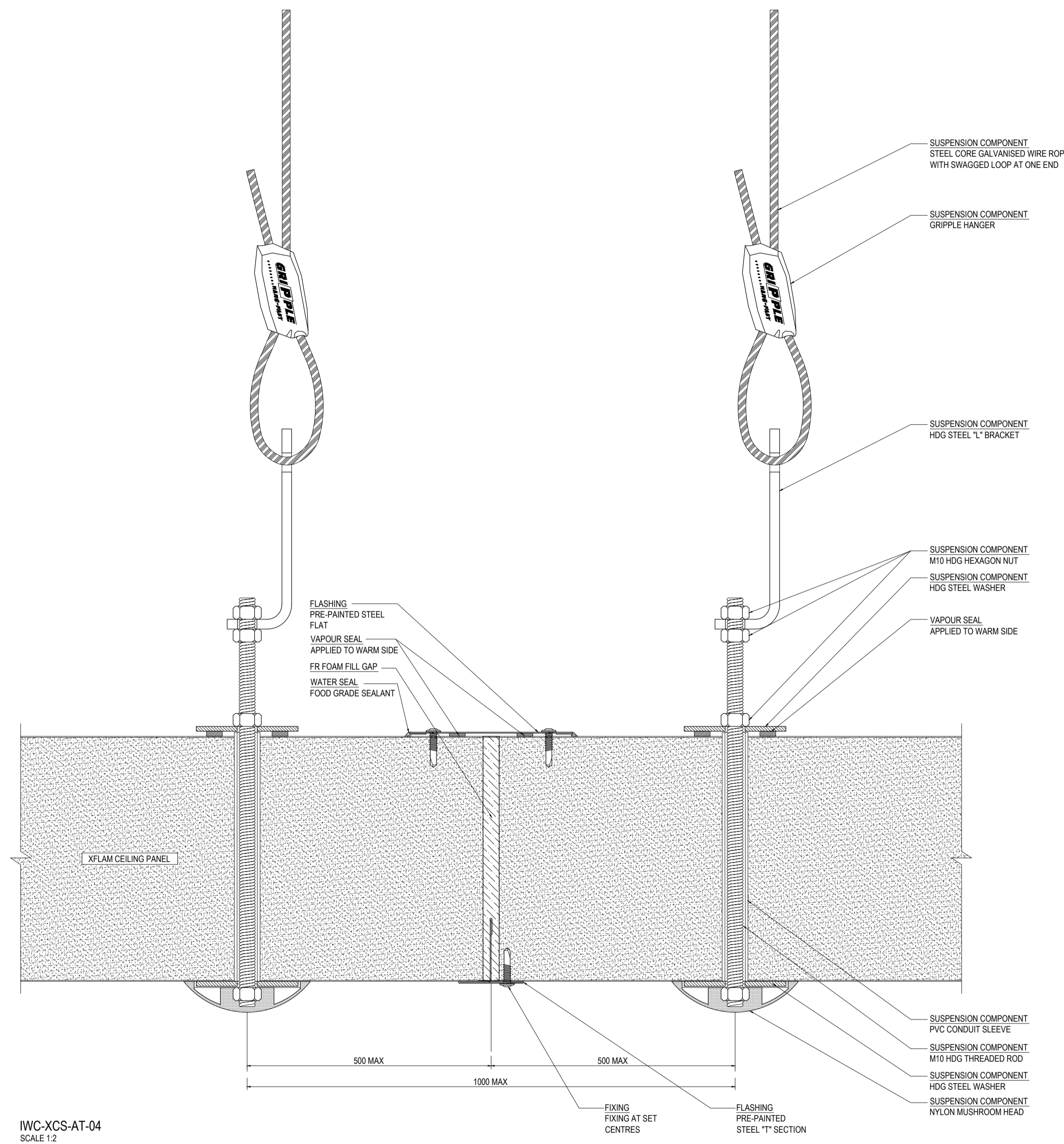

IWC-XCS-AT-04
SCALE 1:2

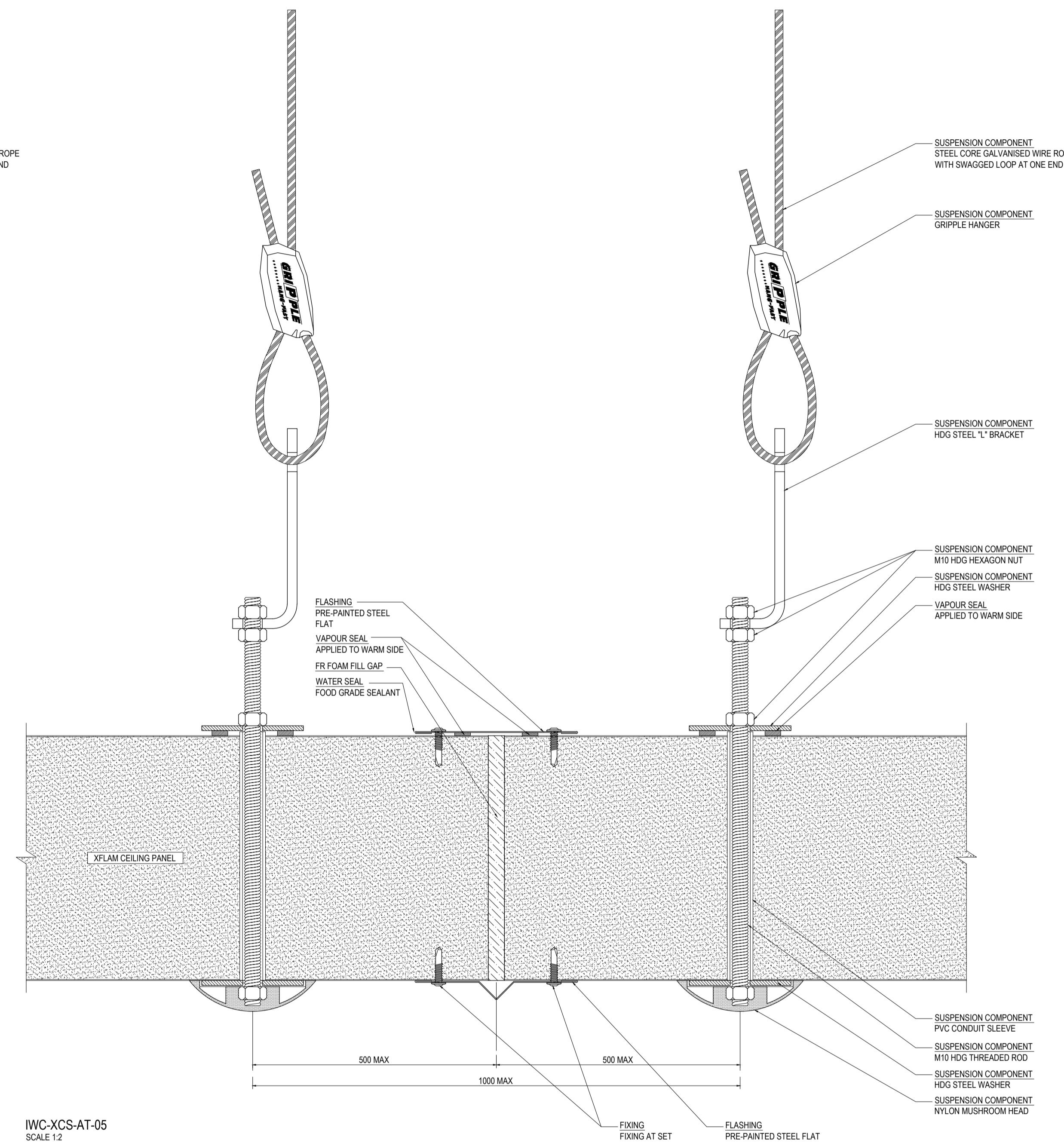

IWC-XCS-AT-05
SCALE 1:2

Revision © copyright

-	-	-
-	-	-
-	-	-
-	-	-
-	-	-
-	-	-

Title
**Standard Details
Ceiling Suspension
Ambient Temperature
(15°C and Above)**

Checked By	AS	Scale	1:2
Drawn By	RV	Sheet size	A1
Issue date	22.01.2013	Revision	A
Drawing No.	IWC-XCS-AT		
Sheet	2 of 11		

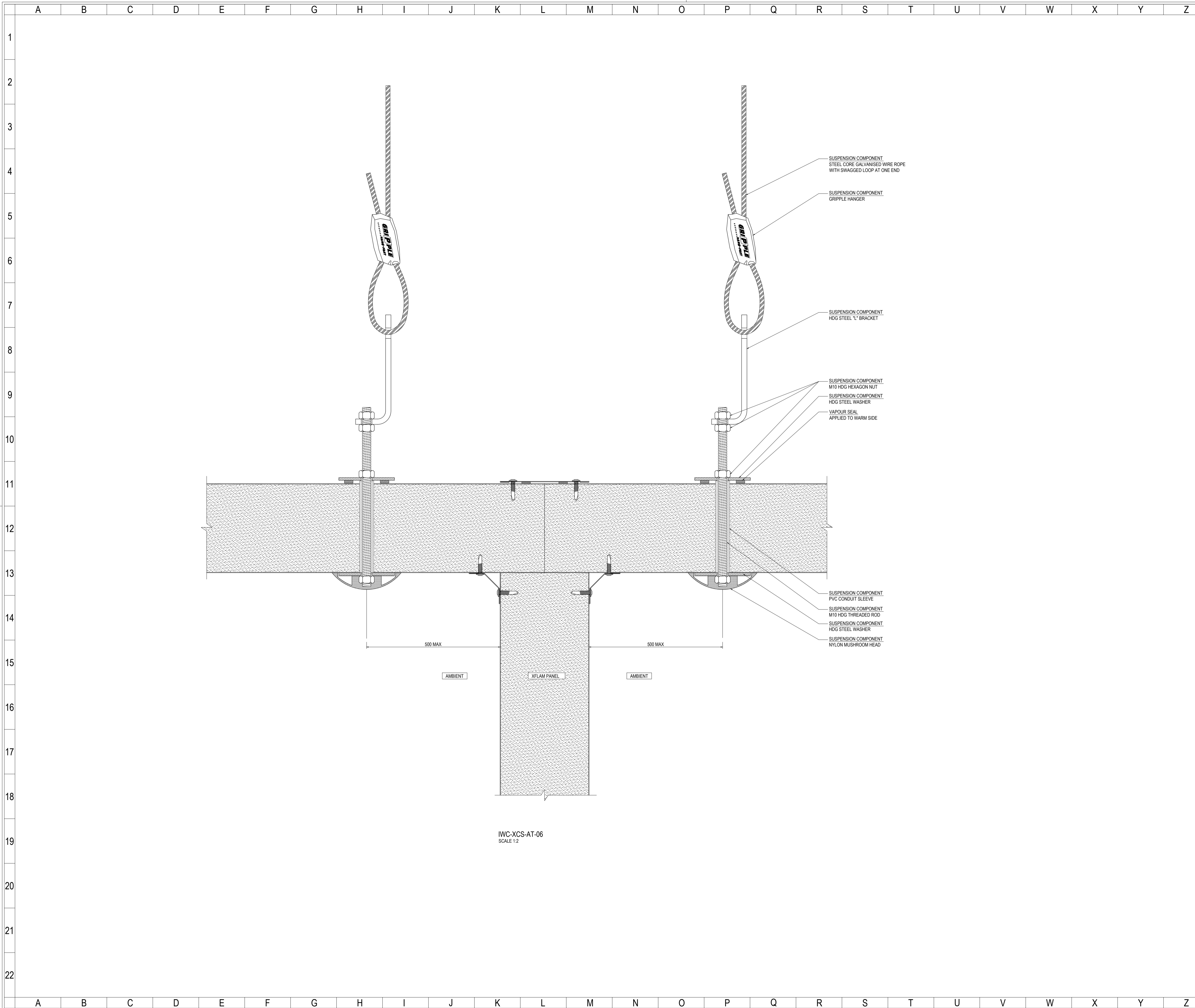

© copyright

Revision		
-	-	-
-	-	-
-	-	-
-	-	-
-	-	-
-	-	-

Title

**Standard Details
Ceiling Suspension
Ambient Temperature
(15°C and Above)**

Checked By	AS	Scale	1:2
Drawn By	RV	Sheet size	A1
Issue date	22.01.2013	Revision	A
Drawing No.	IWC-XCS-AT		
Sheet	3 of 11		

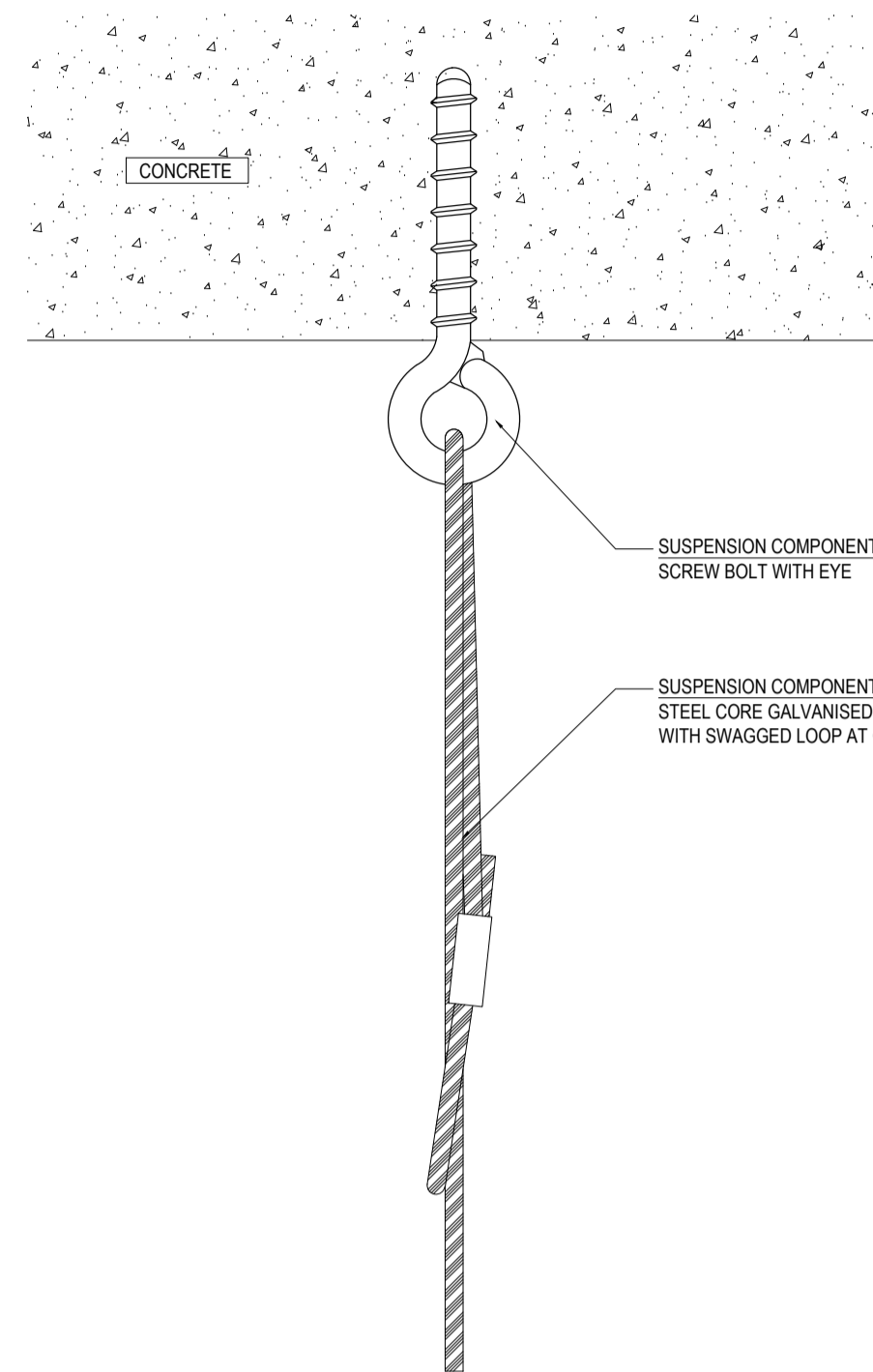

IWC-XCS-AT-07
SCALE 1:2

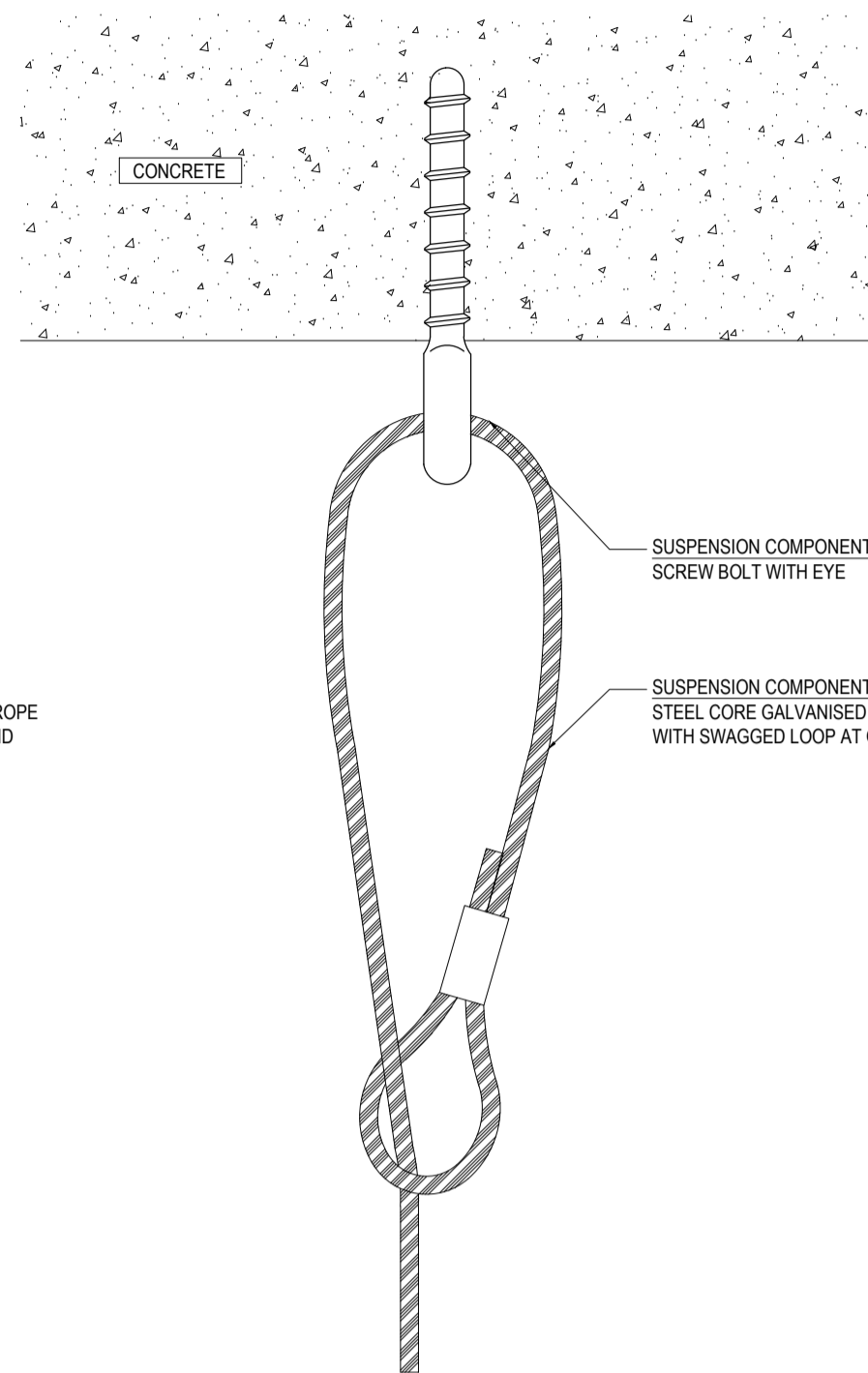

IWC-XCS-AT-08
SCALE 1:2

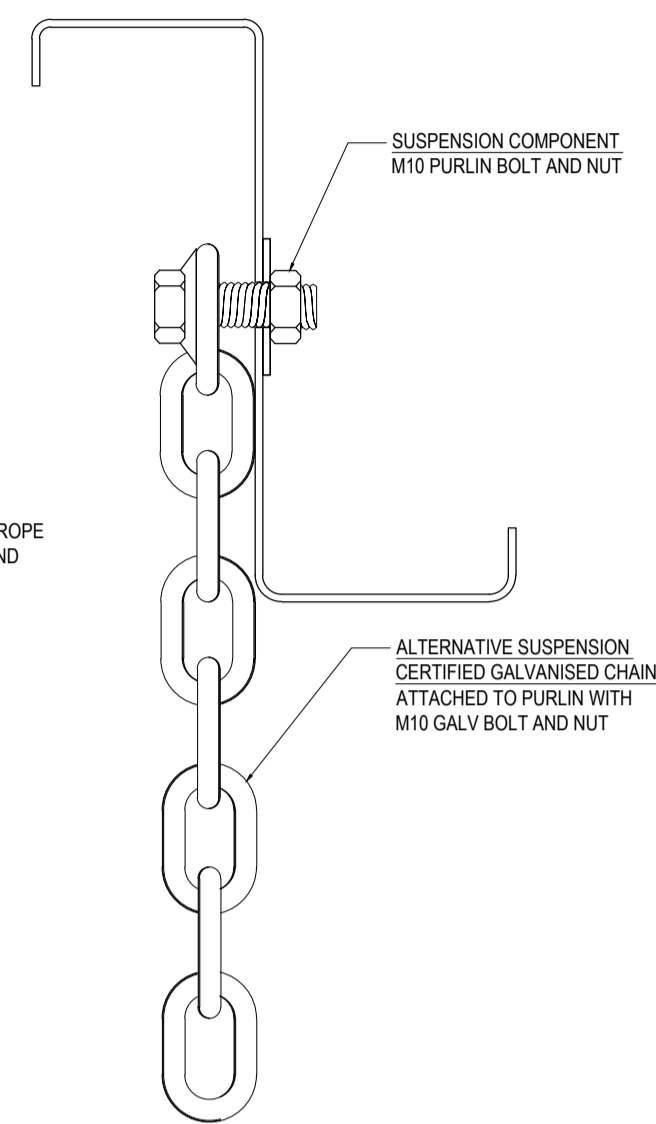

IWC-XCS-AT-09
SCALE 1:2

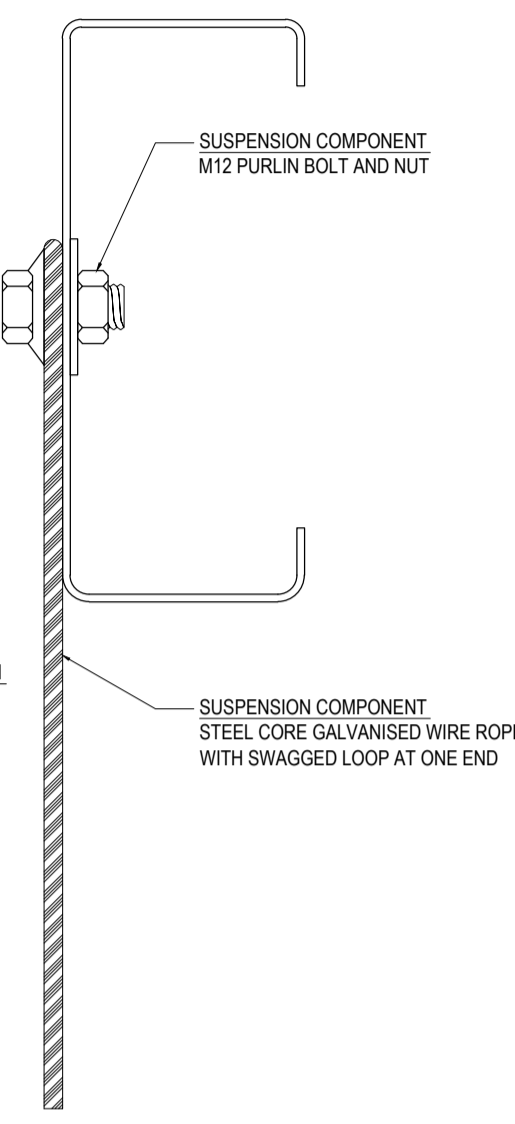

IWC-XCS-AT-10
SCALE 1:2

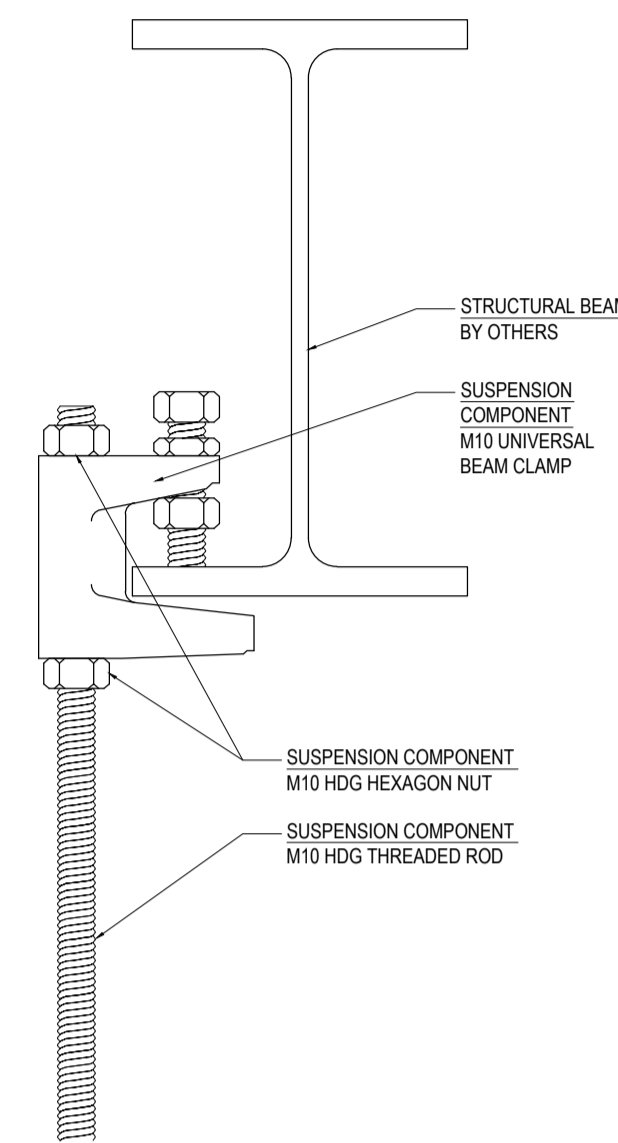

IWC-XCS-AT-13
SCALE 1:2

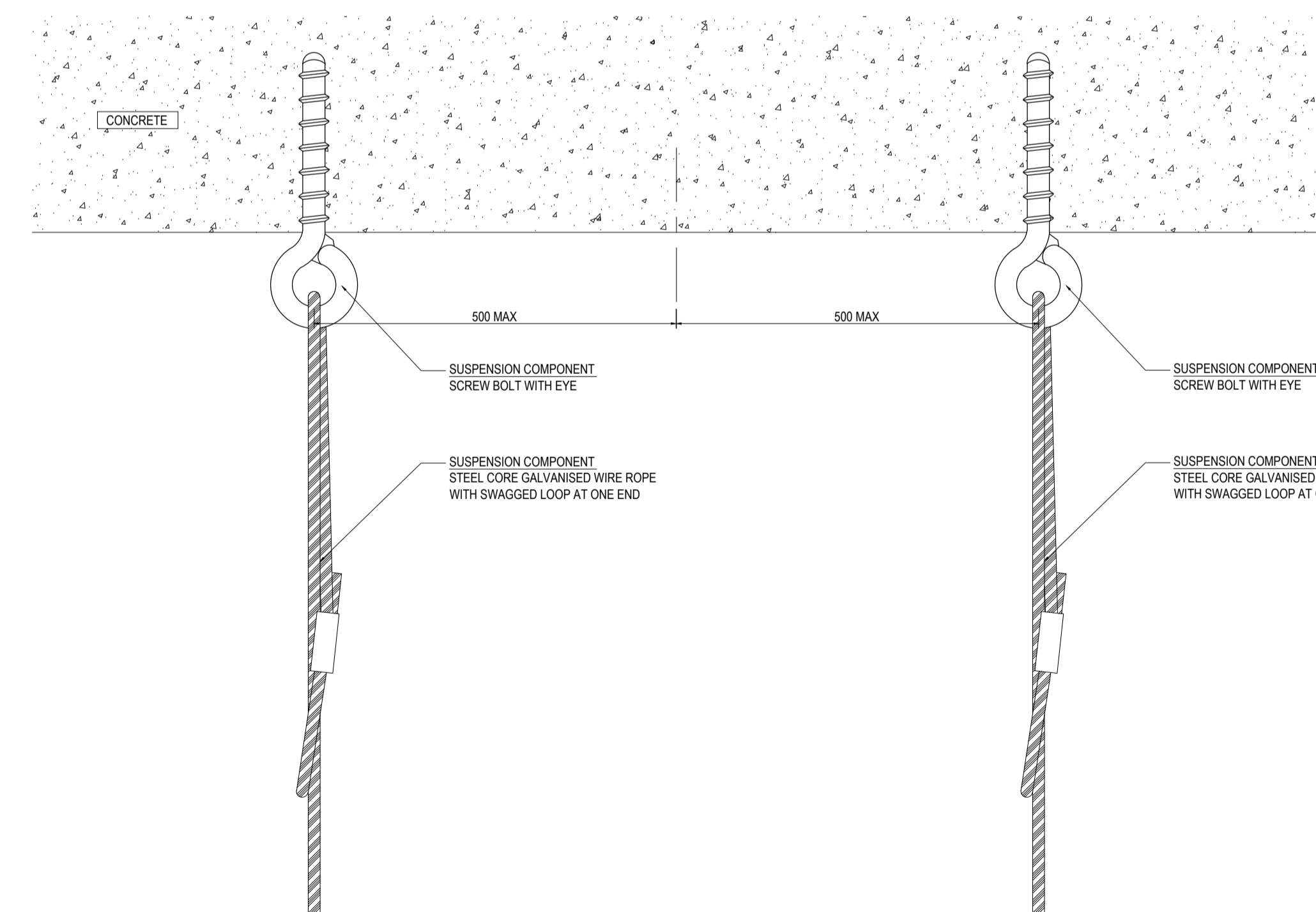

IWC-XCS-AT-14
SCALE 1:2

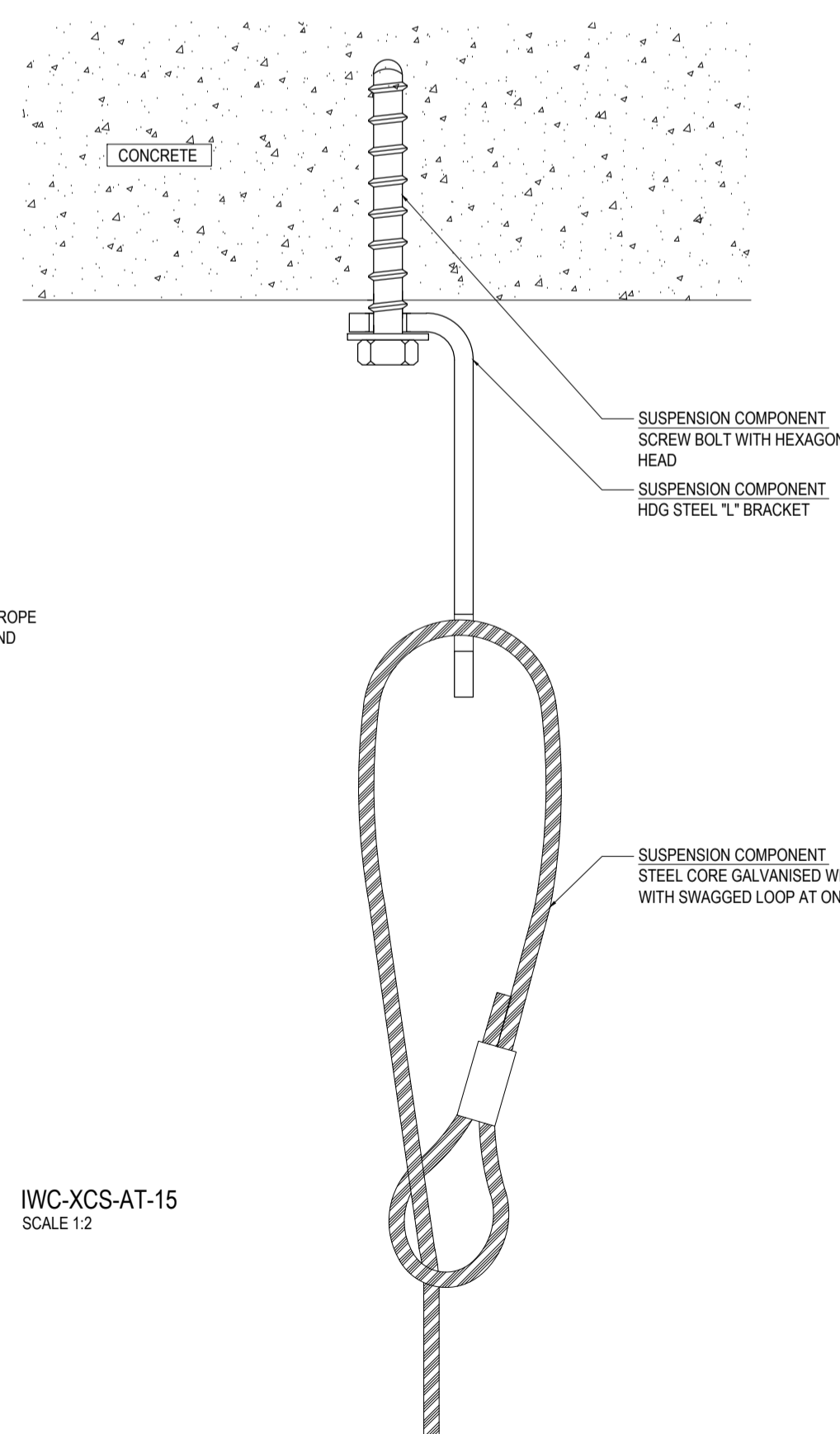

IWC-XCS-AT-15
SCALE 1:2

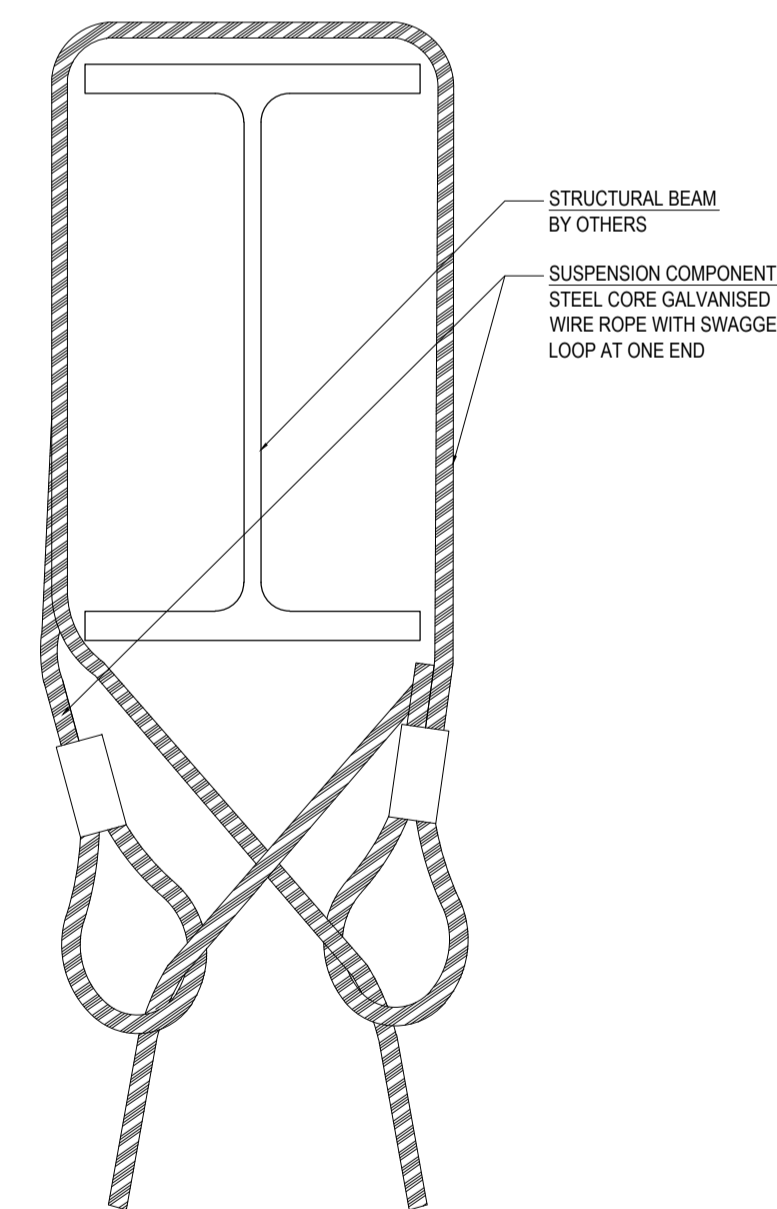

IWC-XCS-AT-16
SCALE 1:2

© copyright

Revision		
-	-	-
-	-	-
-	-	-
-	-	-
-	-	-
-	-	-

Title

**Standard Details
Ceiling Suspension
Ambient Temperature
(15°C and Above)**

Checked By	AS	Scale	1:2
Drawn By	RV	Sheet size	A1
Issue date	22.01.2013	Revision	A
Drawing No.	IWC-XCS-AT		
Sheet	4 of 11		

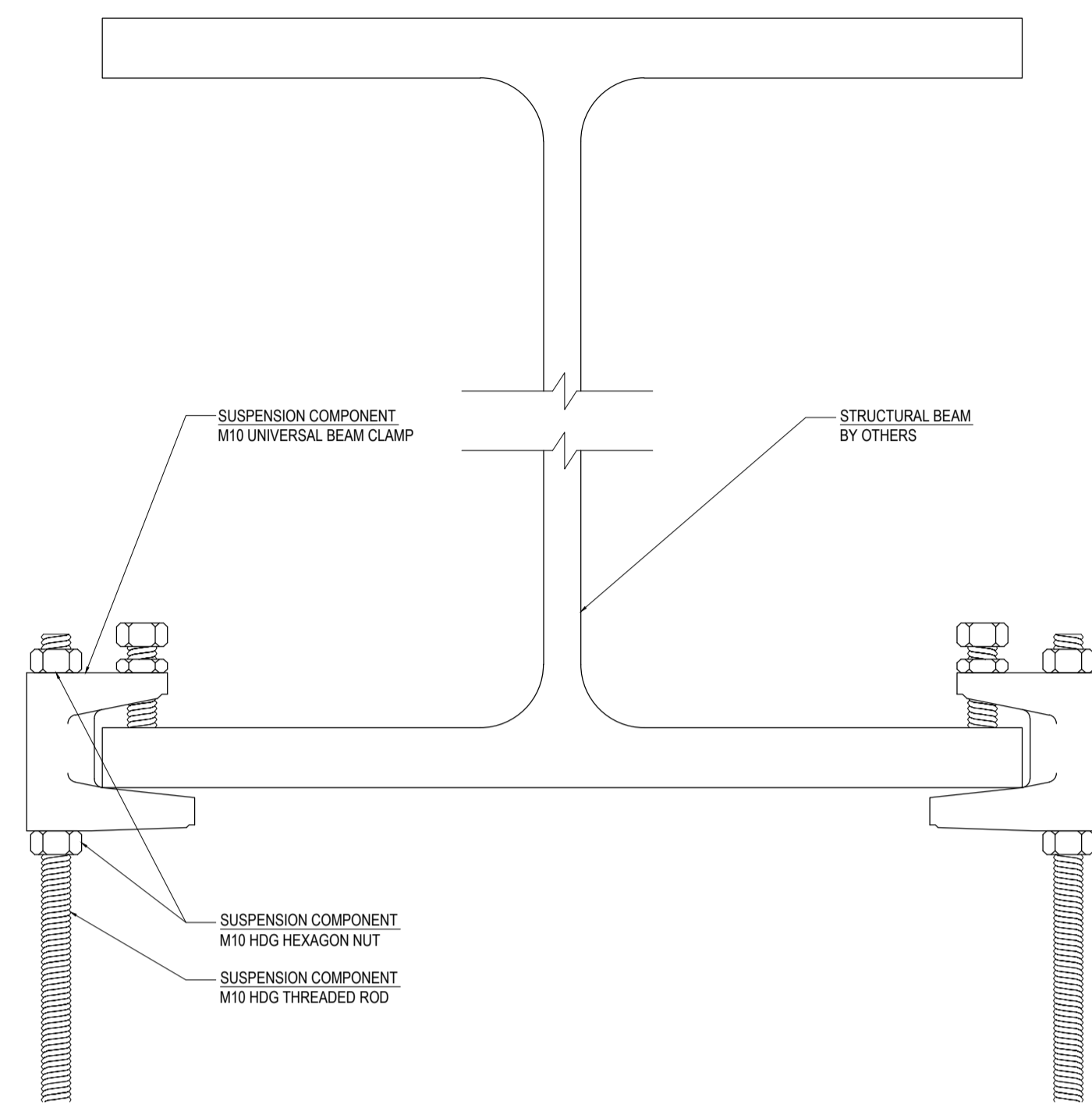

IWC-XCS-AT-17
SCALE 1:2

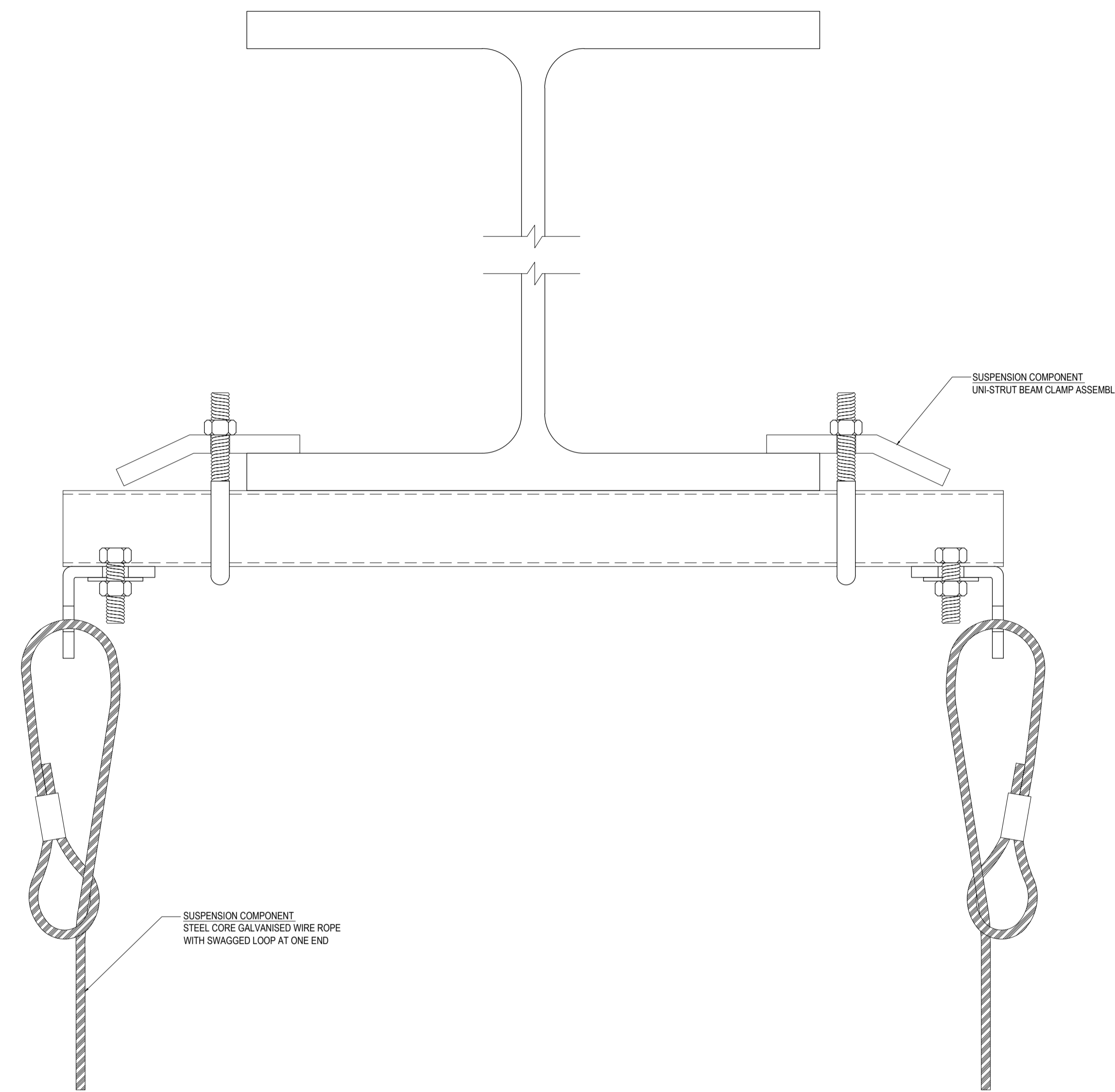

IWC-XCS-AT-18
SCALE 1:2

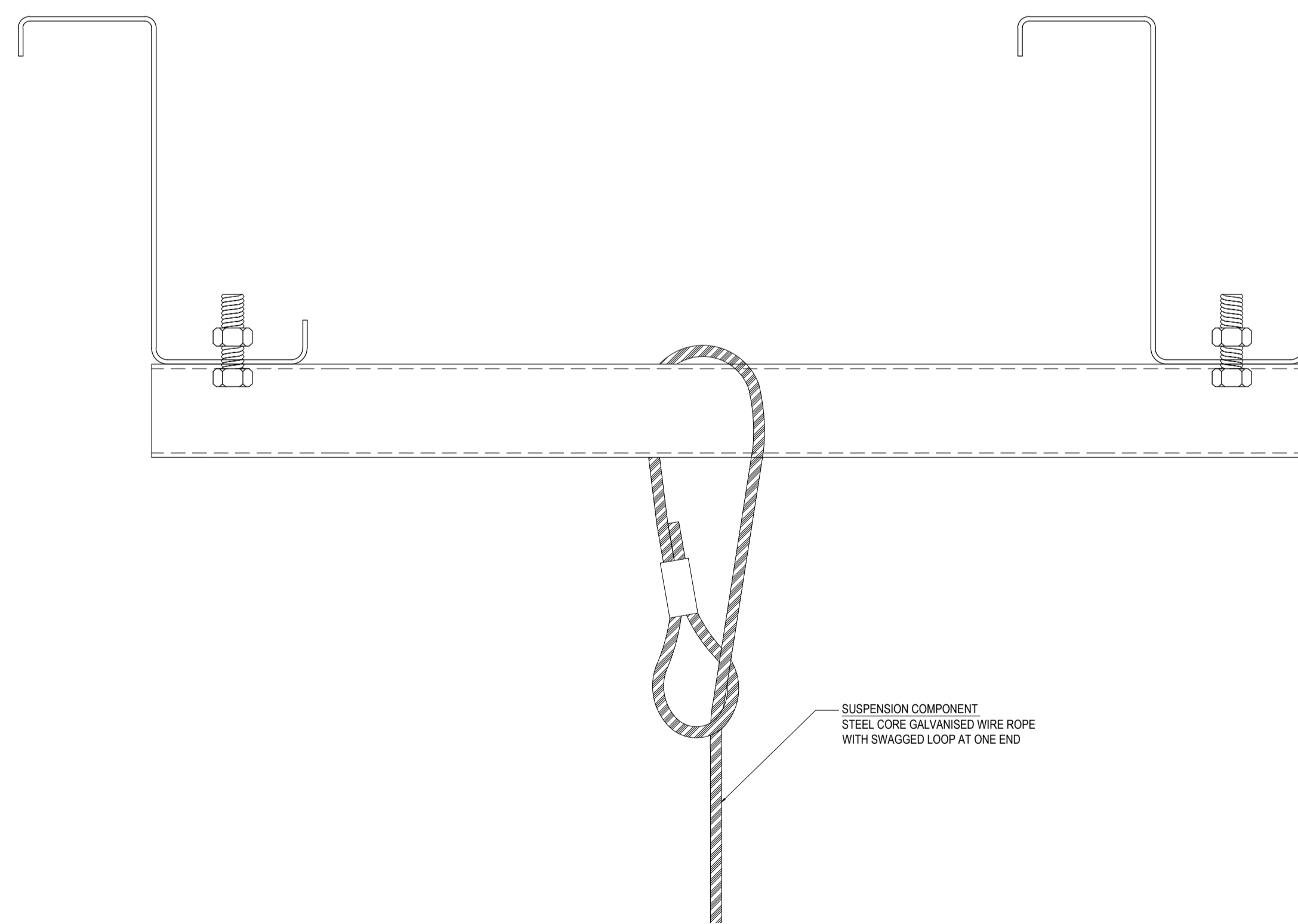

IWC-XCS-AT-19
SCALE 1:2

© copyright

Revision		
-	-	-
-	-	-
-	-	-
-	-	-
-	-	-
-	-	-

Title

**Standard Details
Ceiling Suspension
Ambient Temperature
(15°C and Above)**

Checked By	AS	Scale	1:2
Drawn By	RV	Sheet size	A1
Issue date	22.01.2013	Revision	A
Drawing No.	IWC-XCS-AT		
Sheet	5 of 11		

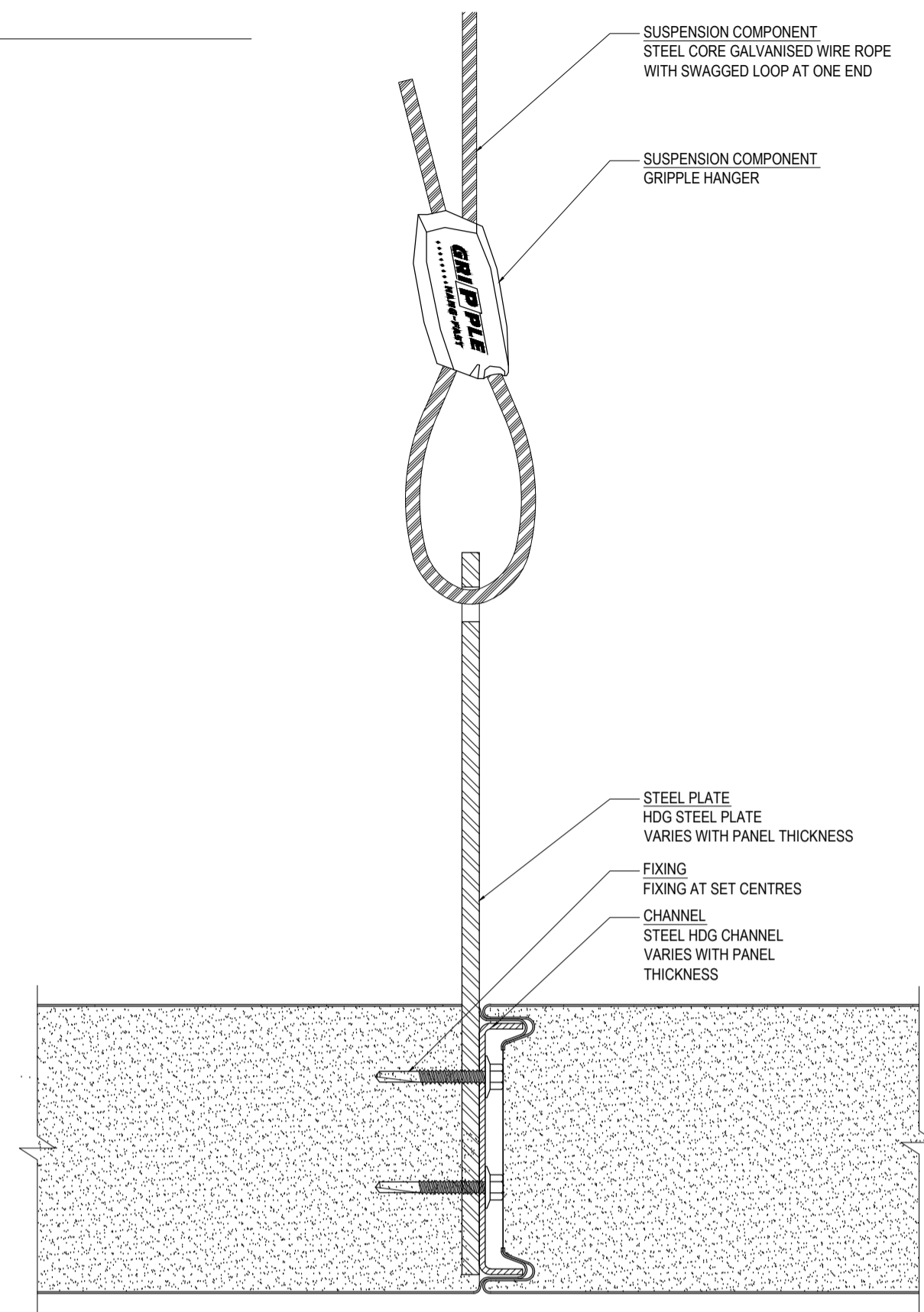

IWC-XCS-AT-20
SCALE 1:2

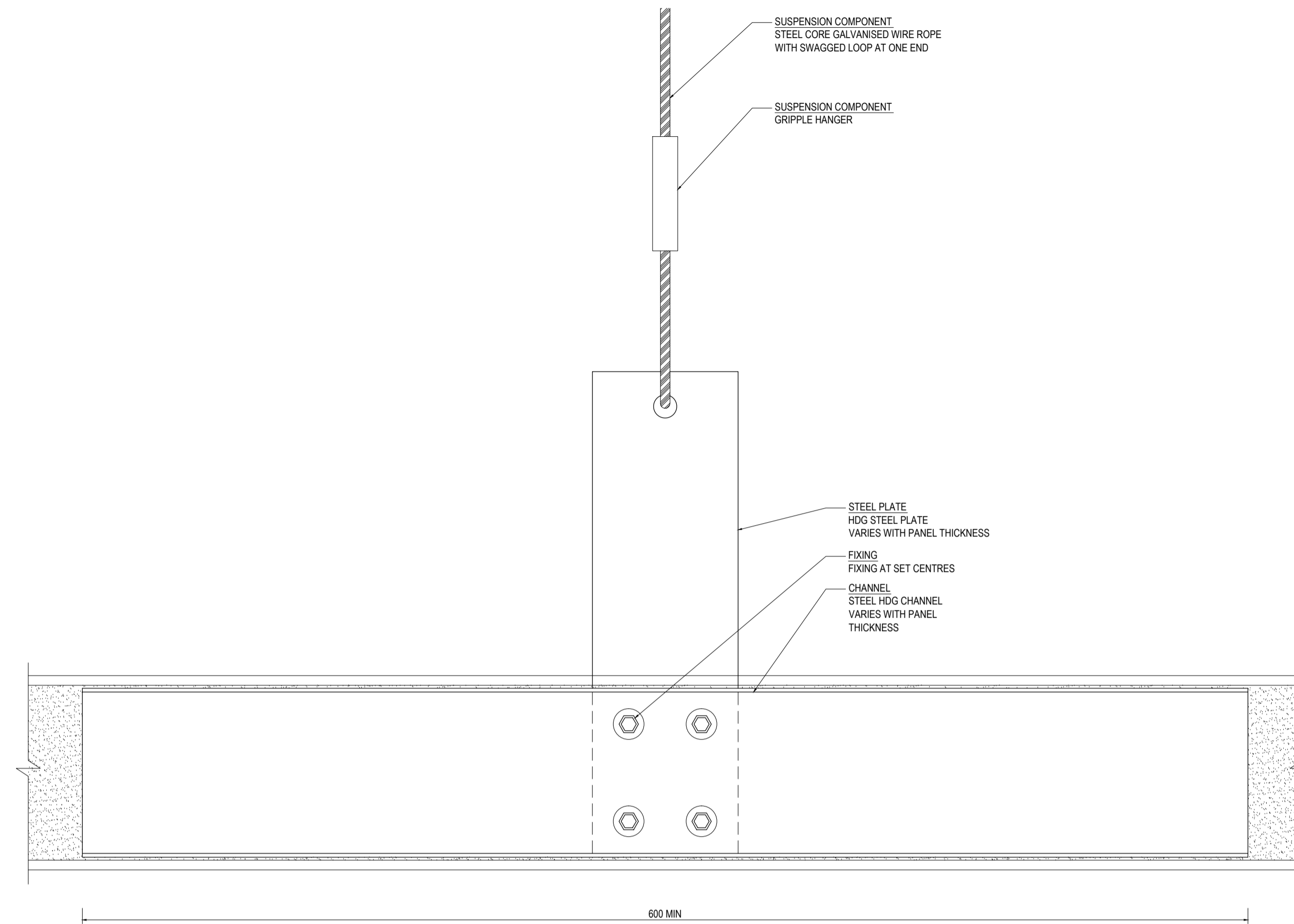

IWC-XCS-AT-21
SCALE 1:2

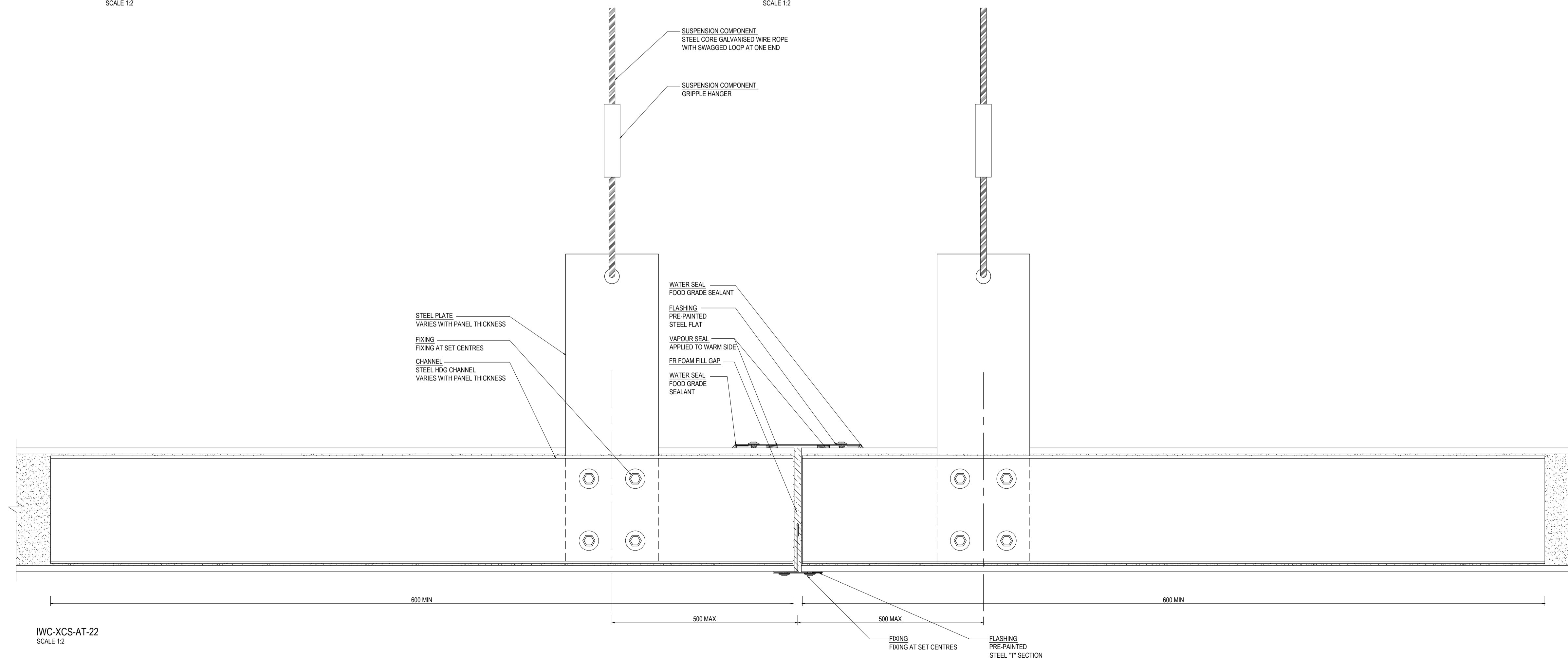

IWC-XCS-AT-22
SCALE 1:2

© copyright

Revision		
-	-	-
-	-	-
-	-	-
-	-	-
-	-	-
-	-	-

Title

**Standard Details
Ceiling Suspension
Ambient Temperature
(15°C and Above)**

Checked By	AS	Scale	1:2
Drawn By	RV	Sheet size	A1
Issue date	22.01.2013	Revision	A
Drawing No.	IWC-XCS-AT		
Sheet	6 of 11		

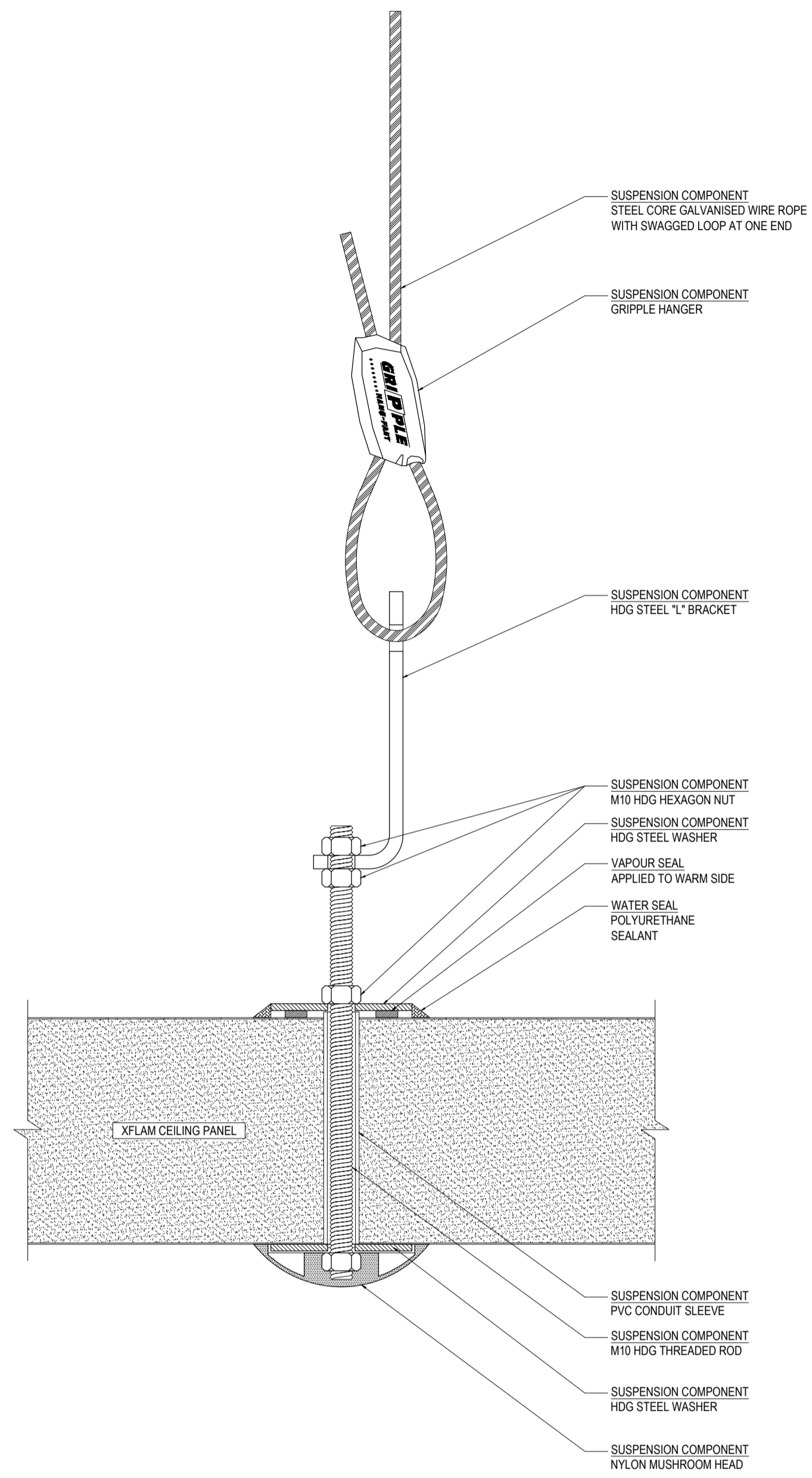

IWC-XCS-ML-01
SCALE 1:2

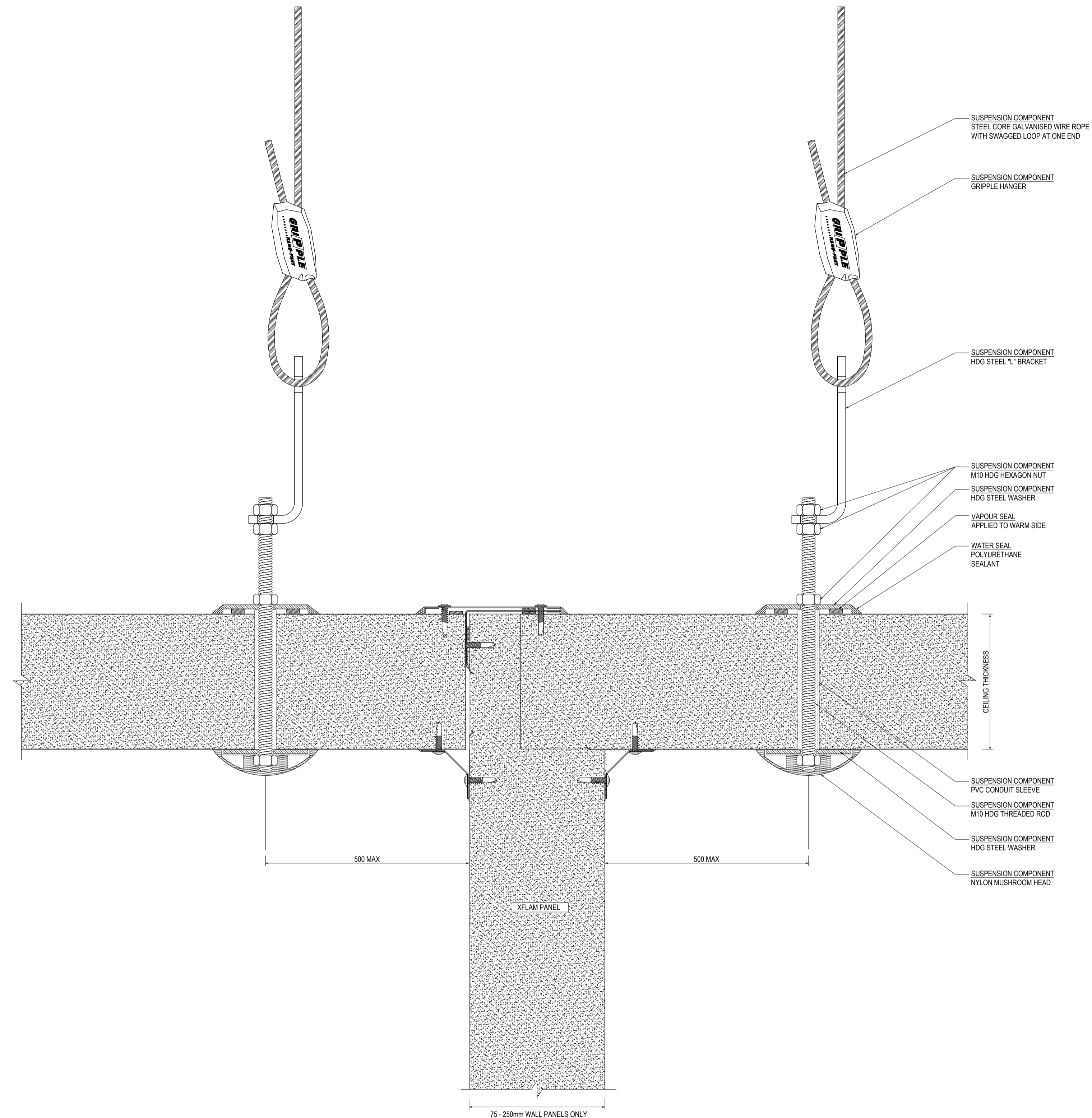

IWC-XCS-ML-02
SCALE 1:2

© copyright

Revision		
-	-	-
-	-	-
-	-	-
-	-	-
-	-	-
-	-	-

Title

**Standard Details
Ceiling Suspension
Medium / Low Temperature
(-50°C - 15°C)**

Checked By	AS	Scale	1:2
Drawn By	RV	Sheet size	A1
Issue date	22.01.2013	Revision	A
Drawing No.	IWC-XCS-ML		
Sheet	7 of 11		

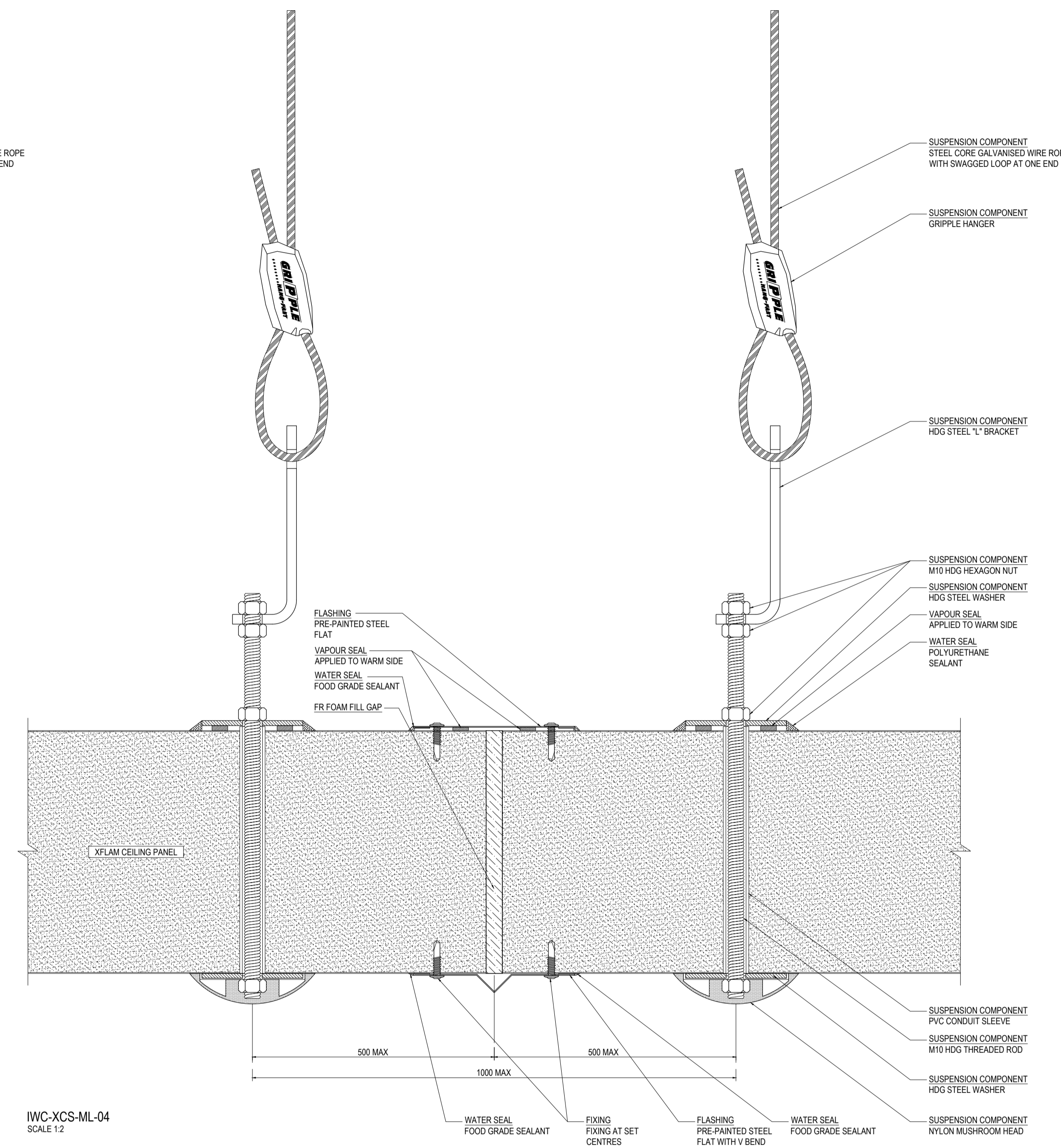
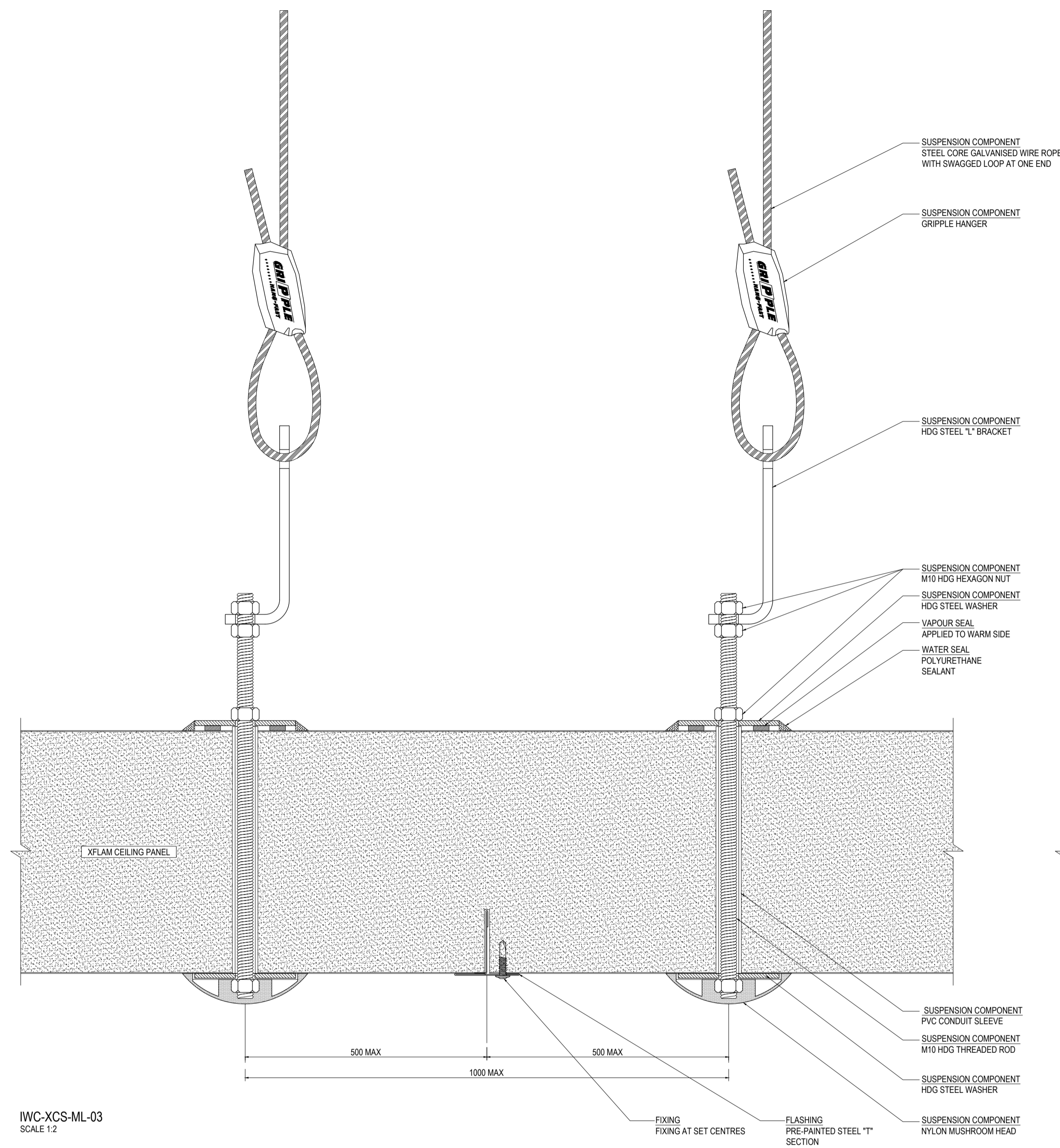

© copyright

Revision		
-	-	-
-	-	-
-	-	-
-	-	-
-	-	-
-	-	-

Title			
Standard Details Ceiling Suspension Medium / Low Temperature (-50°C - 15°C)			
Checked By	AS	Scale	1:2
Drawn By	RV	Sheet size	A1
Issue date	22.01.2013	Revision	A
Drawing No.	IWC-XCS-ML		
Sheet	8 of 11		

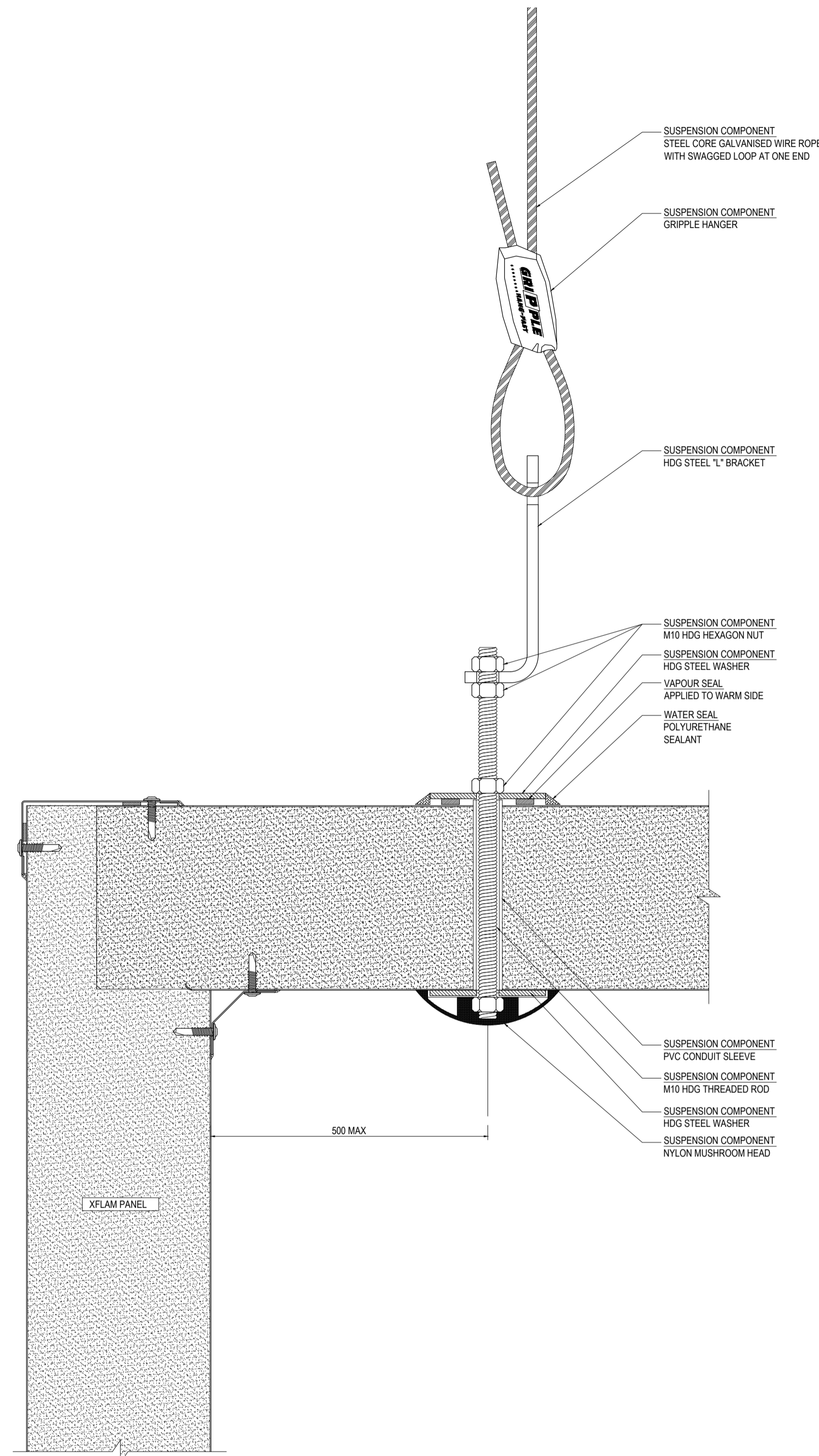

IWC-XCS-ML-05
SCALE 1:2

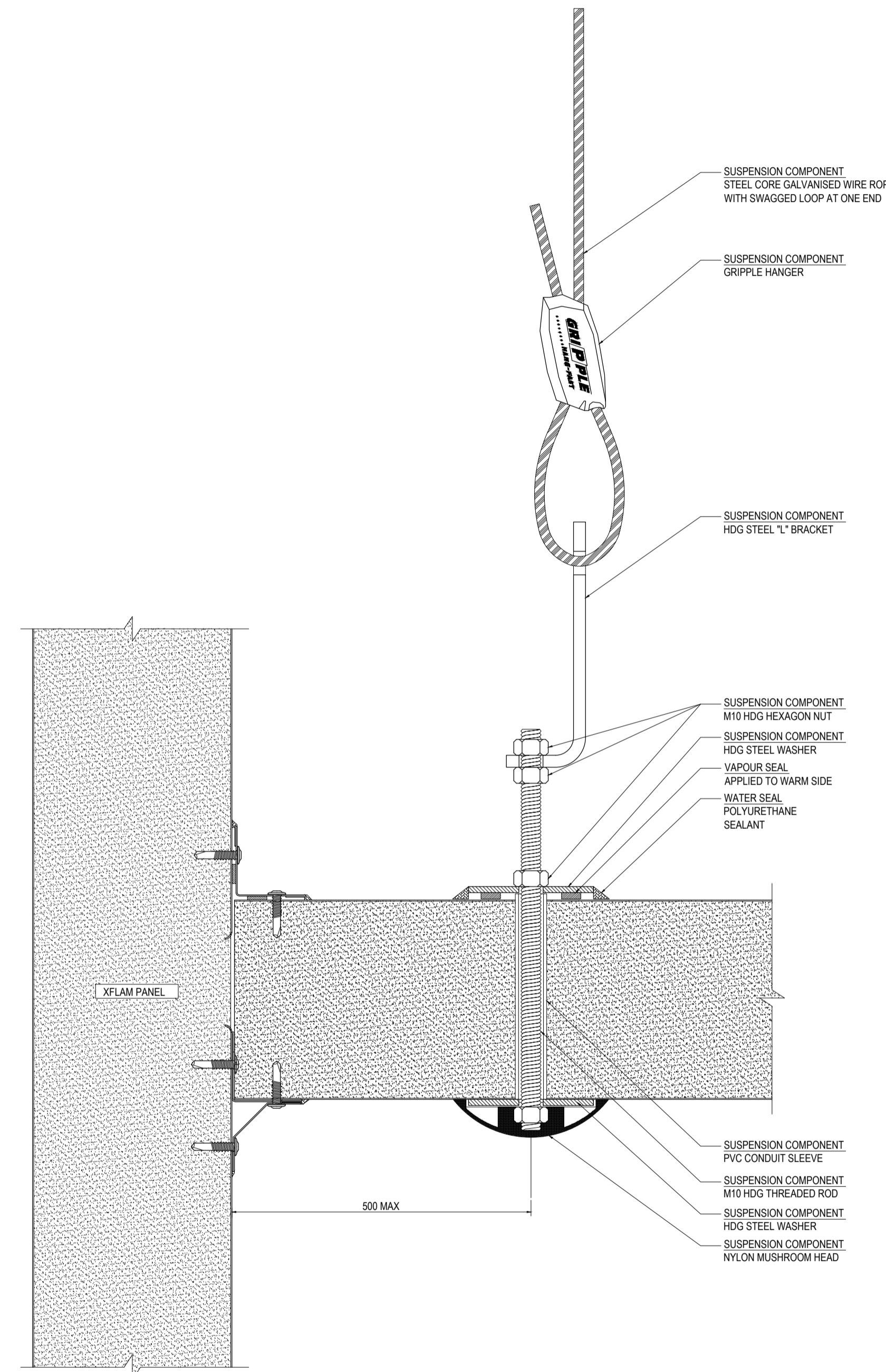

IWC-XCS-ML-06
SCALE 1:2

© copyright

Revision		
-	-	-
-	-	-
-	-	-
-	-	-
-	-	-
-	-	-

Title

**Standard Details
Ceiling Suspension
Medium / Low Temperature
(-50°C - 15°C)**

Checked By	AS	Scale	1:2
Drawn By	RV	Sheet size	A1
Issue date	22.01.2013	Revision	A
Drawing No.	IWC-XCS-ML		
Sheet	9 of 11		

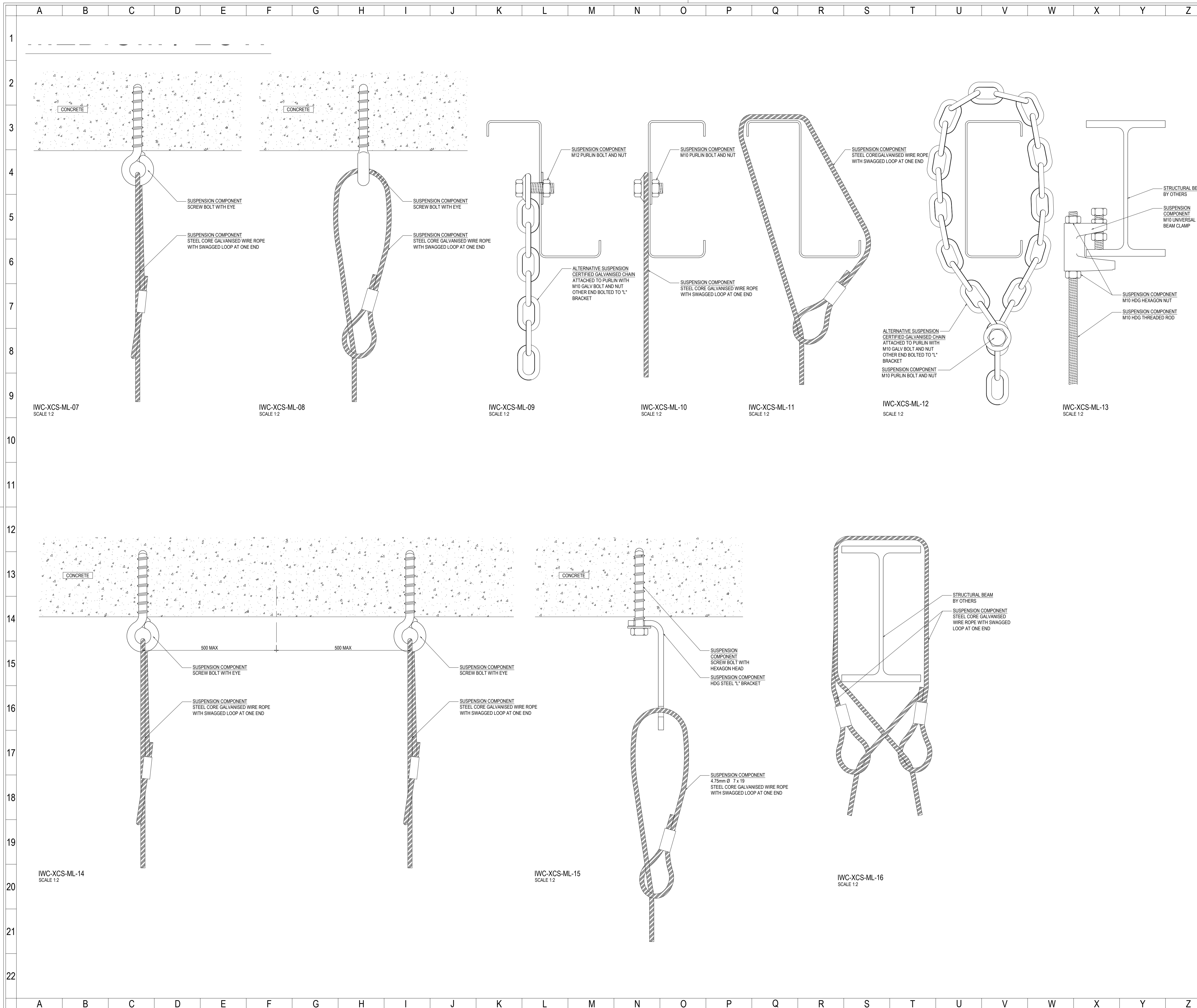

© copyright

Revision		
-	-	-
-	-	-
-	-	-
-	-	-
-	-	-
-	-	-
-	-	-

Title
**Standard Details
Ceiling Suspension
Medium / Low Temperature
(-50°C - 15°C)**

Checked By	AS	Scale	1:2
Drawn By	RV	Sheet size	A1
Issue date	22.01.2013	Revision	A
Drawing No.	IWC-XCS-ML		
Sheet	10 of 11		

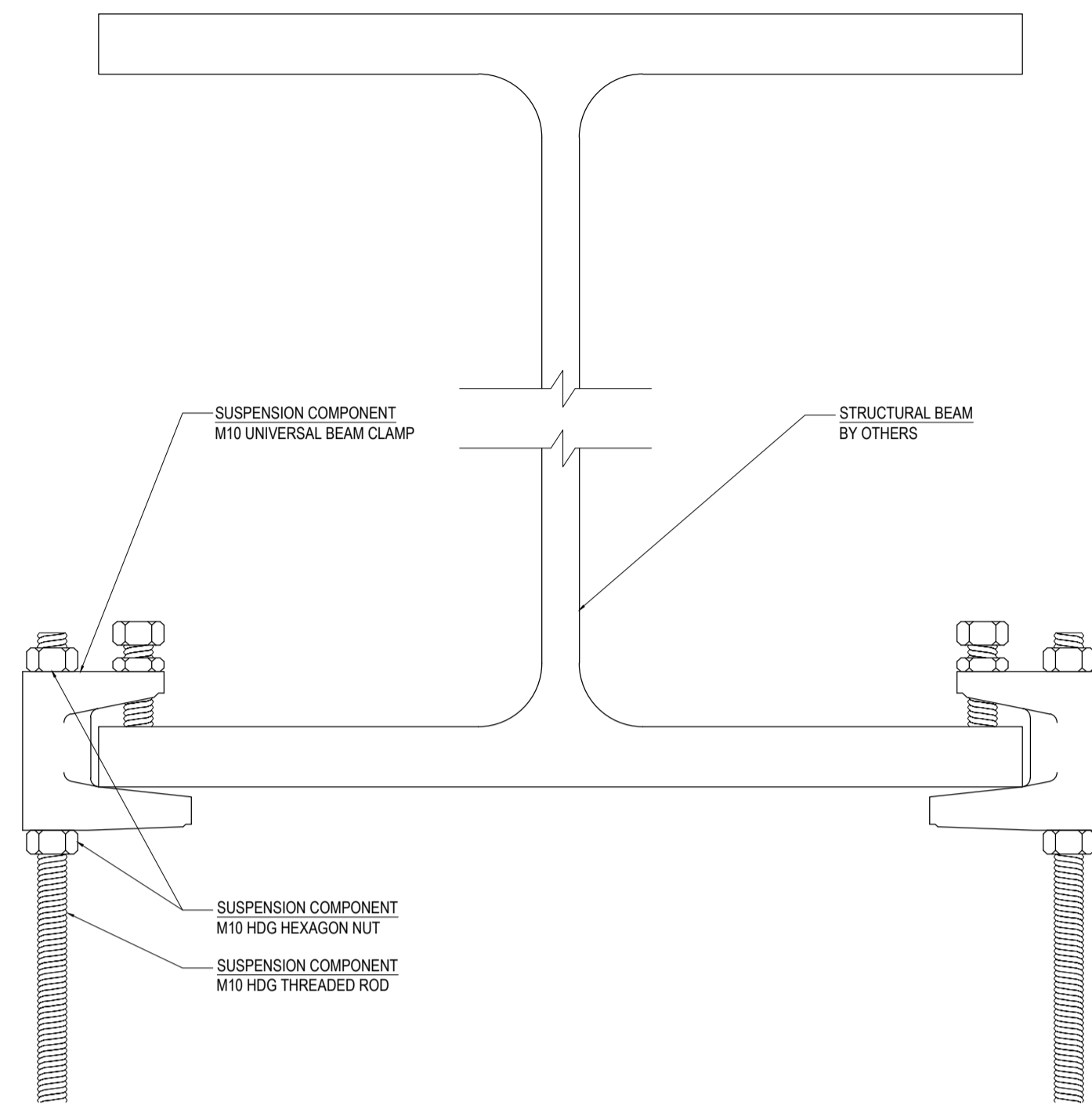

IWC-XCS-ML-17
SCALE 1:2

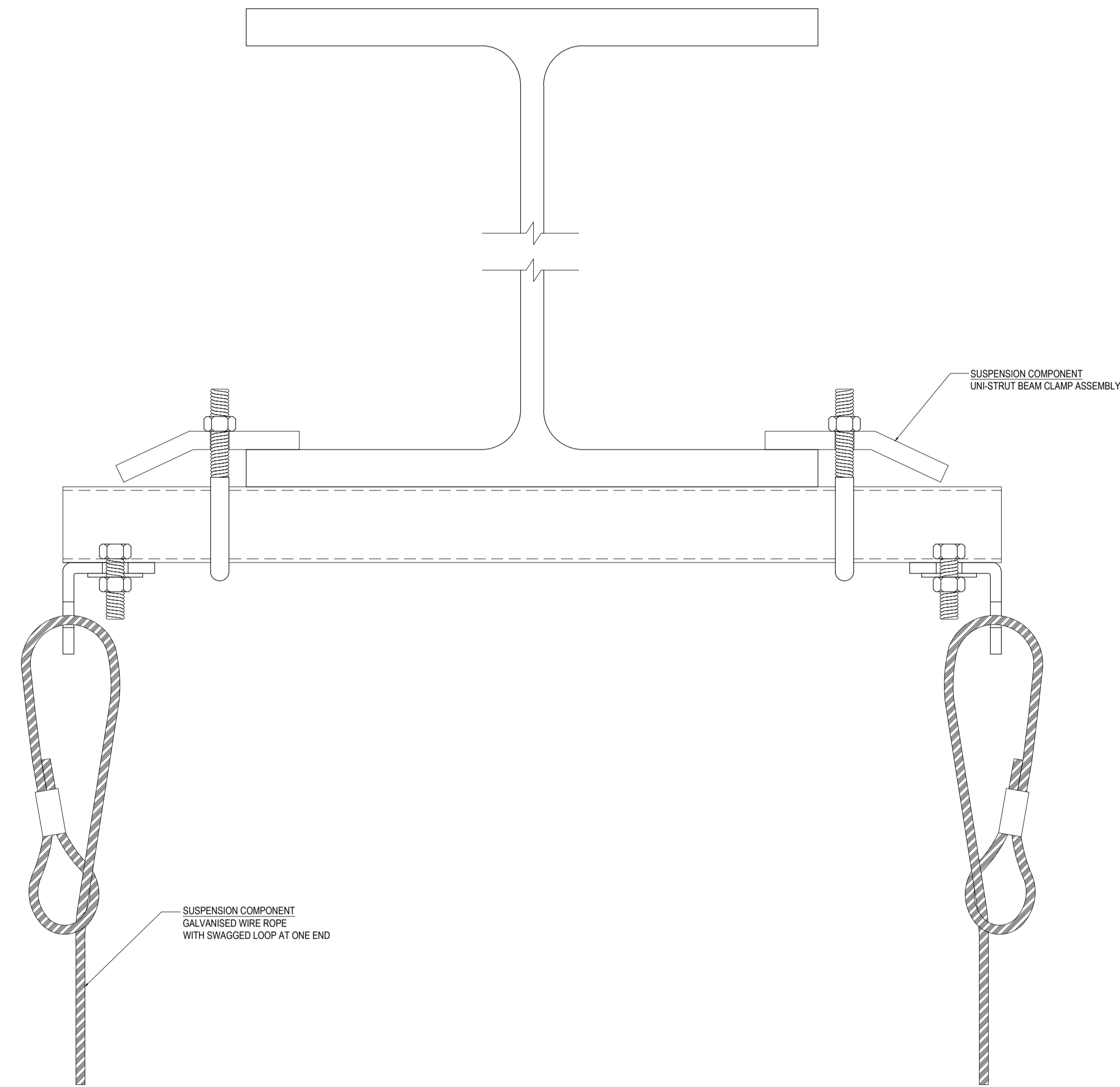

IWC-XCS-ML-18
SCALE 1:2

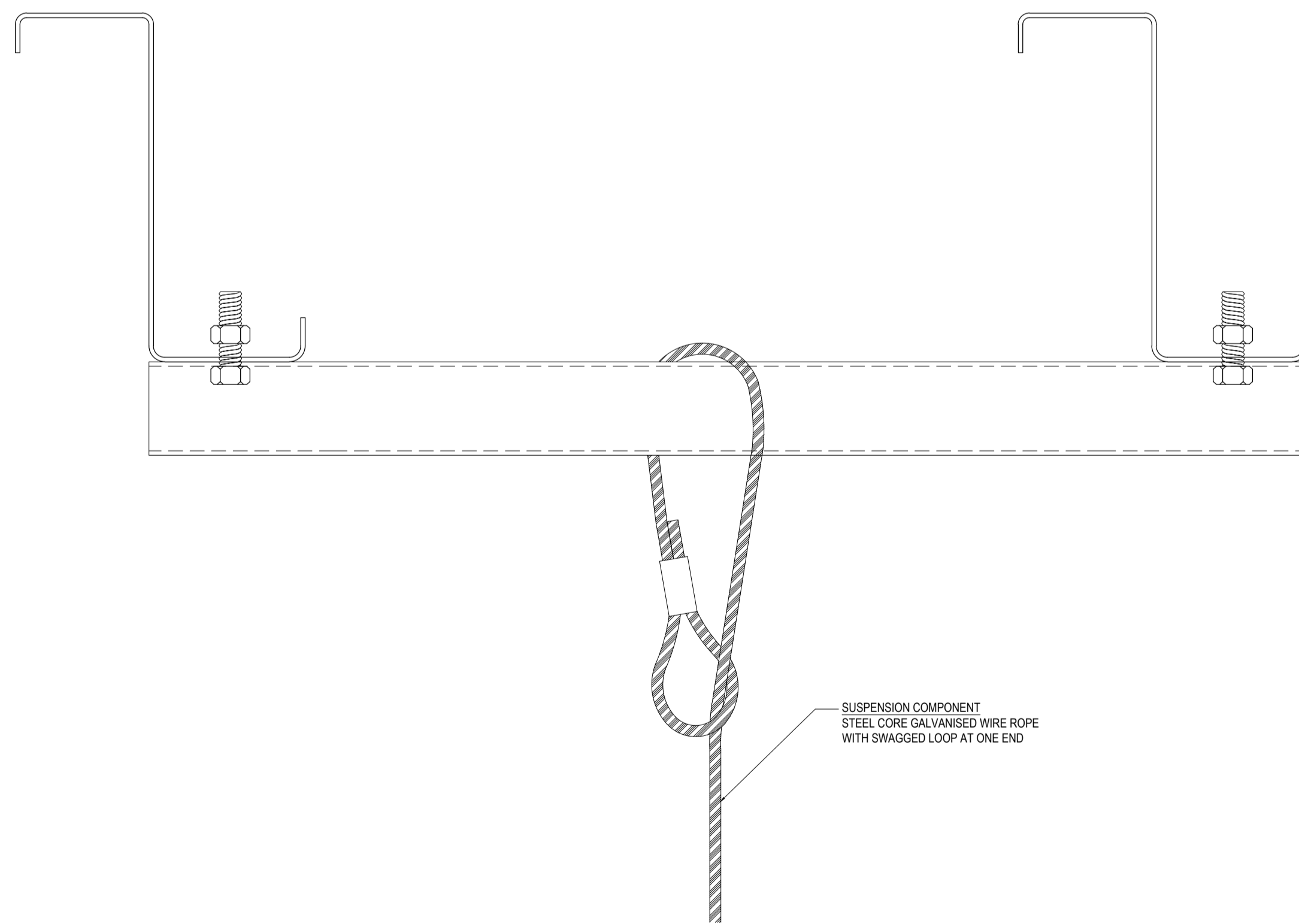

IWC-XCS-ML-19
SCALE 1:2

© copyright

Revision		
-	-	-
-	-	-
-	-	-
-	-	-
-	-	-
-	-	-

Title

**Standard Details
Ceiling Suspension
Medium / Low Temperature
(-50°C - 15°C)**

Checked By	AS	Scale	1:2
Drawn By	RV	Sheet size	A1
Issue date	22.01.2013	Revision	A
Drawing No.	IWC-XCS-ML		
Sheet	11 of 11		